

EXERCISE 7.1

In each of the following, write the correct answer:

1. Which of the following is not a criterion for congruence of triangles?

(a) SAS (b) ASA (c) SSA (d) SSS

Sol. SSA is not a criterion for congruence of triangles.

Hence, (c) is the correct answer.

2. If $AB = QR$, $BC = PR$ and $CA = PQ$, then

(a) $\triangle ABC \cong \triangle PQR$ (b) $\triangle CBA \cong \triangle PRQ$
 (c) $\triangle BAC \cong \triangle RPQ$ (d) $\triangle PQR \cong \triangle BCA$

Sol.

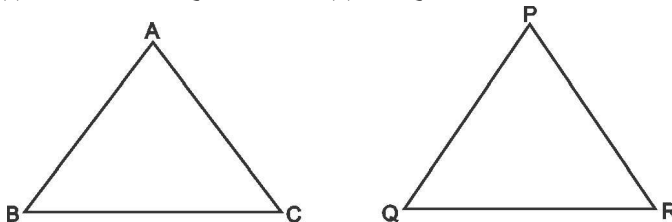

We have $AB = QR$, $BC = PR$ and $CA = PQ$.

There is one-one correspondence between the vertices. That is, P correspondence to C, Q to A and R to B which is written as

$$P \leftrightarrow C, Q \leftrightarrow A, R \leftrightarrow B$$

Under this correspondence, we have

$$\triangle CBA \cong \triangle PRQ$$

Hence, (b) is the correct answer.

3. In $\triangle ABC$, $AB = AC$ and $\angle B = 50^\circ$. Then, $\angle C$ is equal to

(a) 40° (b) 50° (c) 80° (d) 130°

Sol. In $\triangle ABC$, we have

$$AB = AC \quad [\text{Given}]$$

$$\therefore \angle C = \angle B$$

[\because Angles opposite to equal sides are equal]

$$\text{But, } \angle B = 50^\circ$$

$$\therefore \angle C = 50^\circ$$

Hence, (b) is the correct answer.

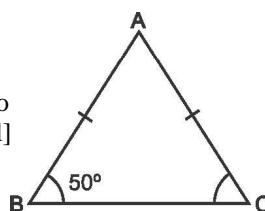

4. In $\triangle ABC$, $BC = AB$ and $\angle B = 80^\circ$. Then, $\angle A$ is equal to

(a) 80° (b) 40° (c) 50° (d) 100°

Sol. In $\triangle ABC$, we have

$$BC = AB \quad [\text{Given}]$$

$$\therefore \angle A = \angle C \quad [\because \text{Angles opposite to equal sides are equal}]$$

$$\text{But, } \angle B = 80^\circ$$

$$\therefore \angle A + \angle B + \angle C = 180^\circ$$

$$\Rightarrow \angle A + 80^\circ + \angle A = 180^\circ$$

$$\Rightarrow 2\angle A = 100^\circ$$

$$\Rightarrow \angle A = 100^\circ \div 2 = 50^\circ$$

Hence, (c) is the correct answer.

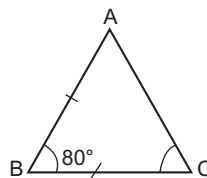

5. In $\triangle PQR$, $\angle R = \angle P$ and $QR = 4$ cm and $PR = 5$ cm.

Then, the length of PQ is

(a) 4 cm (b) 5 cm

(c) 2 cm (d) 2.5 cm

Sol. In $\triangle PQR$, we have $\angle R = \angle P$ [Given]

$$\therefore PQ = QR$$

[\because Sides opposite to equal angles are equal]

Now, $QR = 4$ cm, therefore, $PQ = 4$ cm.

Hence, the length of PQ is 4 cm.

Hence, (a) is the correct answer.

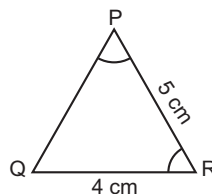

6. D is a point on the side BC of a $\triangle ABC$ such that AD bisects $\angle BAC$. Then,

(a) $BD = CD$ (b) $BA > BD$

(c) $BD > BA$ (d) $CD > CA$

Sol. In $\triangle ADC$,

$$\text{Ext. } \angle ADB > \text{Int. opp. } \angle DAC$$

$$\therefore \angle ADB > \angle BAD$$

$$[\because \angle BAD = \angle DAC]$$

$$\Rightarrow AB > BD$$

[\because Side opposite to greater angle is longer.]

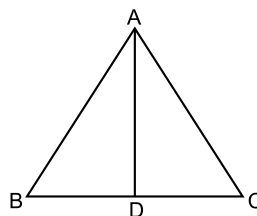

7. It is given that $\triangle ABC \cong \triangle FDE$ and $AB = 5$ cm, $\angle B = 40^\circ$ and $\angle A = 80^\circ$. Then, which of the following is true?

(a) $DF = 5$ cm, $\angle F = 60^\circ$ (b) $DF = 5$ cm, $\angle E = 60^\circ$

(c) $DE = 5$ cm, $\angle E = 60^\circ$ (d) $DE = 5$ cm, $\angle D = 60^\circ$

Sol.

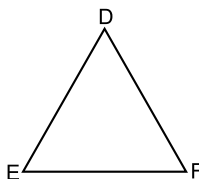
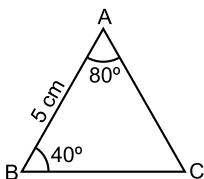

It is given that $\triangle ABC \cong \triangle FDE$ and $AB = 5$ cm, $\angle B = 40^\circ$ and $\angle A = 80^\circ$, so $\angle C = 60^\circ$.

The sides of $\triangle ABC$ fall on corresponding equal sides of $\triangle FDE$. A corresponds to F, B corresponds to D, and C corresponds to E.

So, only $DF = 5\text{ cm}$, $\angle E = 60^\circ$ is true.

Hence, (b) is the correct answer.

8. Two sides of a triangle are of lengths 5 cm and 1.5 cm. The length of the third side of the triangle cannot be

(a) 3.6 cm (b) 4.1 cm (c) 3.8 cm (d) 3.4 cm

Sol. Since sum of any two sides of a triangle is always greater than the third side, so third side of the triangle cannot be 3.4 cm because then $1.5\text{ cm} + 3.4\text{ cm} = 4.9 < \text{third side} (5\text{ cm})$.

Hence, (d) is the correct answer.

9. In $\triangle PQR$, if $\angle R > \angle Q$, then

(a) $QR > PR$ (b) $PQ > PR$
(c) $PQ < PR$ (d) $QR < PR$

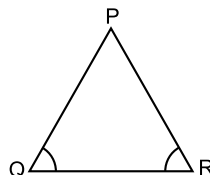

Sol. In $\triangle PQR$, we have $\angle R > \angle Q$

$\therefore PQ > PR$ [\because Side opposite to greater angle is longer]

Hence, (b) is the correct answer.

10. In triangles ABC and PQR, $AB = AC$, $\angle C = \angle P$ and $\angle B = \angle Q$. The two triangles are

(a) isosceles but not congruent.
(b) isosceles and congruent.
(c) congruent but not isosceles.
(d) neither congruent nor isosceles.

Sol. $AB = AC$ [Given]
 $\therefore \angle B = \angle C$ [\because Angles opposite to equal sides are equal]

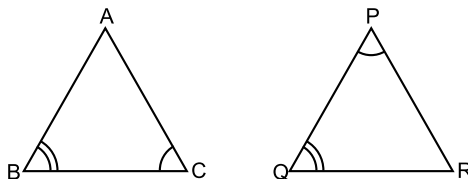

Also, $\angle B = \angle Q$ and $\angle C = \angle P$ [Given]

$\therefore \angle Q = \angle P$

$\Rightarrow PR = RQ$ [\because Sides opp. to equal \angle s equal]

Hence, (a) is the correct option.

11. In triangles ABC and DEF, $AB = FD$ and $\angle A = \angle D$. The two triangles will be congruent by SAS axiom. Then,

(a) $BC = EF$ (b) $AC = DE$ (c) $AC = EF$ (d) $BC = DE$

Sol. (b) $AC = DE$.

EXERCISE 7.2

1. In triangles ABC and PQR, $\angle A = \angle Q$ and $\angle B = \angle R$.

Which side of ΔPQR should be equal to side AB of ΔABC so that the

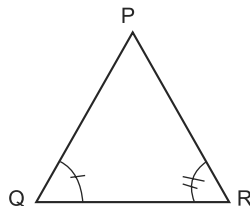
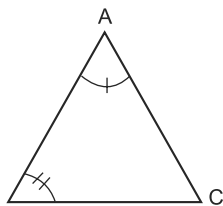

two triangles are congruent? Give reasons for your answer.

Sol. In triangles ABC and PQR, we have

$$\angle A = \angle Q$$

[Given]

$$\angle B = \angle R$$

[Given]

For the triangles to be congruent, we must have $AB = QR$. They will be congruent by ASA congruence rule.

2. In triangles ABC and PQR, $\angle A = \angle Q$ and $\angle B = \angle R$.

Which side of ΔPQR should be equal to side BC of ΔABC so that the

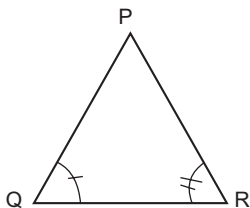
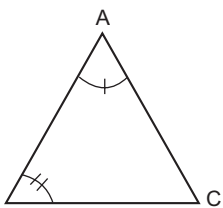

two triangles are congruent? Give reasons for your answer.

Sol. In triangles ABC and PQR, we have

$$\angle A = \angle Q \text{ and } \angle B = \angle R$$

[Given]

For the triangles to be congruent, we must have

$$BC = RP$$

They will be congruent by AAS congruence rule.

3. “If two sides and an angle of one triangle are equal to two sides and an angle of another triangle, then the two triangles must be congruent.” Is the statement true? Why?

Sol. This statement is not true. Angles must be the included angles.

4. “If two angles and a side of one triangle are equal to two angles and a side of another triangle, then the two triangles must be congruent.” Is the statement true? Why?

Sol. This statement is true. Sides must be corresponding sides.

5. Is it possible to construct a triangle with lengths of sides 4 cm, 3 cm and 7 cm? Give reasons for your answer.

Sol. We know that the sum of any two sides of a triangle is always greater than the third side.

Here, the sum of two sides whose lengths are

$$4 \text{ cm and } 3 \text{ cm} = 4 \text{ cm} + 3 \text{ cm} = 7 \text{ cm,}$$

which is equal to the length of third side, i.e., 7 cm.

Hence, it is not possible to construct a triangle with lengths of sides 4 cm, 3 cm and 7 cm.

6. It is given that $\triangle ABC \cong \triangle RPQ$. Is it true to say that $BC = QR$? Why?

Sol. It is false that $BC = QR$ because $BC = PQ$ as $\triangle ABC \cong \triangle RPQ$.

7. It is given that $\triangle PQR \cong \triangle EDF$, then is it true to say that $PR = EF$? Give reasons for your answer.

Sol. Yes, $PR = EF$ because they are the corresponding sides of $\triangle PQR$ and $\triangle EDF$.

8. In $\triangle PQR$, $\angle P = 70^\circ$ and $\angle R = 30^\circ$. Which side of this triangle is the longest? Give reasons for your answer.

Sol. In $\triangle PQR$, we have

$$\begin{aligned}\angle Q &= 180^\circ - (\angle P + \angle R) \\ &= 180^\circ - (70^\circ + 30^\circ) = 180^\circ - 100^\circ = 80^\circ\end{aligned}$$

Now, in $\triangle PQR$, $\angle Q$ is the larger (greater) and side opposite to greater angle is longer.

Hence, PR is the longest side.

9. AD is a median of the triangle ABC . Is it true that $AB + BC + CA > 2AD$? Give reason for your answer.

Sol. In $\triangle ABD$, we have

$$AB + BD > AD \quad \dots(1)$$

[\because Sum of the lengths of any two sides of a triangle must be greater than the third side]

Now, in $\triangle ADC$, we have

$$AC + CD > AD \quad \dots(2)$$

[\because Sum of the lengths of any two sides of a triangle must be greater than the third side]

Adding (1) and (2), we get

$$AB + BD + CD + AC > 2AD$$

$$\Rightarrow AB + BC + CA > 2AD \quad [\because BD = CD \text{ as } AD \text{ is median of } \triangle ABC]$$

10. M is a point on side BC of a triangle ABC such that AM is the bisector of $\angle BAC$. Is it true to say that perimeter of the triangle is greater than $2AM$? Give reason for your answer.

Sol. We have to prove that

$$AB + BC + AC > 2AM.$$

As sum of any two sides of a triangle is greater than the third side, so in $\triangle ABM$, we have

$$AB + BM > AM \quad \dots(1)$$

$$\text{and in } \triangle ACM, \quad AC + CM > AM \quad \dots(2)$$

Adding (1) and (2), we get

$$AB + BM + AC + CM > 2AM$$

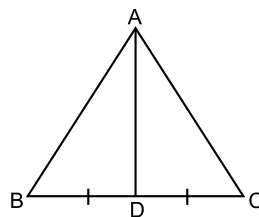

$$\text{or } AB + (BM + CM) + AC > 2AM$$

$$\Rightarrow AB + BC + AC > 2AM$$

Hence, it is true to say that perimeter of the triangle is greater than $2AM$.

11. Is it possible to construct a triangle with lengths of sides as 9 cm, 7 cm and 17 cm? Give reason for your answer.

Sol. No, it is not possible to construct a triangle whose sides are 9 cm, 7cm and 17cm because

$$9 \text{ cm} + 7 \text{ cm} = 16 \text{ cm} < 17 \text{ cm}$$

where as sum of any two sides of a triangle is always greater than the third side.

12. Is it possible to construct a triangle with lengths of its sides as 8 cm, 7 cm and 4 cm? Give reason for your answer.

Sol. Yes, it is possible to construct a triangle with lengths of sides as 8 cm, 7 cm and 4 cm as sum of any two sides of a triangle is greater than the third side.

EXERCISE 7.3

1. ABC is an isosceles triangle with $AB = AC$ and BD and CE are its two medians. Show that $BD = CE$.

Sol. Given : $\triangle ABC$ with $AB = AC$
and $AD = CD$, $AE = BE$.

To prove : $BD = CE$

Proof : In $\triangle ABC$, we have

$$AB = AC \quad [\text{Given}]$$

$$\Rightarrow \frac{1}{2}AB = \frac{1}{2}AC$$

$$\Rightarrow AE = AD$$

[\because D is the mid-point of AC and E is the mid-point of AB]

Now, in $\triangle ABD$ and $\triangle ACE$, we have

$$AB = AC \quad [\text{Given}]$$

$$\angle A = \angle A \quad [\text{Common angle}]$$

$$AE = AD \quad [\text{Proved above}]$$

So, by SAS criterion of congruence, we have

$$\triangle ABD \cong \triangle ACE$$

$$\Rightarrow BD = CE \quad [\text{CPCT}]$$

Hence, proved.

2. In the given figure, D and E are points on side BC of a $\triangle ABC$ such that $BD = CE$ and $AD = AE$. Show that $\triangle ABD \cong \triangle ACE$.

Sol. Given : $\triangle ABC$ in which $BD = CE$ and $AD = AE$.

To prove: $\triangle ABD \cong \triangle ACE$

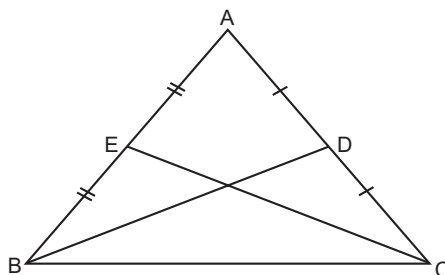

Proof : In $\triangle ADE$, we have

$$AD = AE \quad [\text{Given}]$$

$$\Rightarrow \angle 2 = \angle 1$$

[\because Angles opposite to equal sides of a triangle are equal]

$$\text{Now, } \angle 1 + \angle 3 = 180^\circ \quad \dots(1)$$

[Linear pair axiom]

$$\angle 2 + \angle 4 = 180^\circ \quad \dots(2)$$

[Linear pair axiom]

From equations (1) and (2), we get

$$\angle 1 + \angle 3 = \angle 2 + \angle 4$$

$$\Rightarrow \angle 3 = \angle 4 \quad [\because \angle 1 = \angle 2]$$

Now, in $\triangle ABD$ and $\triangle ACE$, we have

$$AD = AE \quad [\text{Given}]$$

$$\angle 3 = \angle 4 \quad [\text{Proved above}]$$

$$BD = CE \quad [\text{Given}]$$

So, by SAS criterion of congruence, we have

$$\triangle ABD \cong \triangle ACE$$

Hence, proved.

3. CDE is an equilateral triangle formed on a side CD of a square ABCD (See fig.). Show that $\triangle ADE \cong \triangle BCE$.

Sol. Given : An equilateral triangle CDE formed on side CD of square ABCD.

To prove : $\triangle ADE \cong \triangle BCE$

Proof : In square ABCD, we have

$$\angle 1 = \angle 2 \quad \dots (1) \quad [\because \text{Each} = 90^\circ]$$

Now, in $\triangle DCE$, we have

$$\angle 3 = \angle 4 \quad \dots(2) \quad [\because \text{Each} = 60^\circ]$$

Adding (1) of (2), we get

$$\angle 1 + \angle 3 = \angle 2 + \angle 4$$

$$\Rightarrow \angle ADE = \angle BCE$$

Now, in $\triangle ADE$ and $\triangle BCE$, we have

$$DE = CE \quad [\text{Sides of an equilateral triangle are equal}]$$

$$\angle ADE = \angle BCE \quad [\text{Proved above}]$$

$$AD = BC \quad [\text{Sides of a square are equal in length}]$$

So, by SAS criterion of congruence, we have

$$\triangle ADE \cong \triangle BCE$$

Hence, proved

4. In the given figure, $BA \perp AC$, $DE \perp DF$ such that $BA = DE$ and $BF = EC$. Show that $\triangle ABC \cong \triangle DEF$.

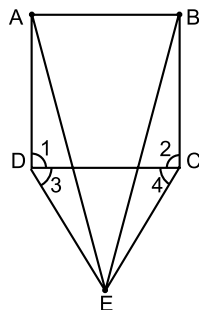
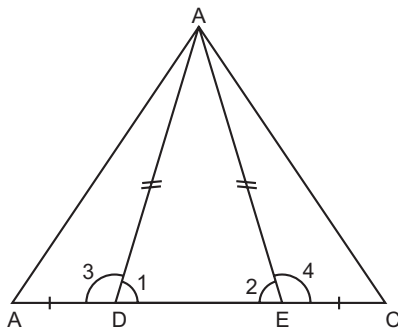

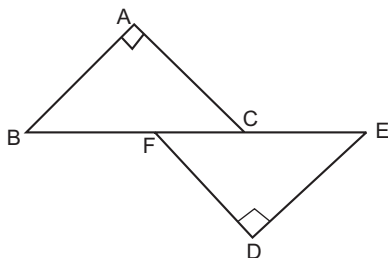

Sol. We have $BF = EC$

$$\therefore BF + FC = CE + FC \Rightarrow BC = EF$$

In $\triangle ABC$, $\angle A = 90^\circ$ and in $\triangle DEF$, $\angle D = 90^\circ$.

$\therefore \triangle ABC$ and $\triangle DEF$ are right triangles.

Now, in right triangles ABC and DEF , we have

$$BA = DE \quad \text{[Given]}$$

$$\text{and} \quad BC = EF \quad \text{[Proved above]}$$

$$\therefore \triangle ABC \cong \triangle DEF \quad \text{[By RHS congruence rule]}$$

5. O is a point on the side SR of a $\triangle PSR$ such that $PQ = PR$. Prove that $PS > PQ$.

Sol. Given : $PQ = PR$

To prove: $PS > PQ$

Proof: In $\triangle PRQ$, we have

$$PR = PQ \quad \text{[Given]}$$

$$\Rightarrow \angle 1 = \angle R$$

[\therefore Angles opposite to equal sides of a triangle are equal]

$$\text{But,} \quad \angle 1 > \angle S \quad \text{[\therefore Exterior angle of a triangle is greater than each of the remote interior angles]}$$

$$\Rightarrow \angle R > \angle S \quad \text{[$\therefore \angle 1 = \angle R$]}$$

$$\Rightarrow PS > PR \quad \text{[\therefore In a triangle, side opposite to the large is longer]}$$

Hence, proved.

6. S is any point on side QR of a $\triangle PQR$. Show that $PQ + QR + RP > 2PS$.

Sol. Given: A point S on side QR of $\triangle PQR$.

To prove : $PQ + QR + RP > 2PS$

Proof : In $\triangle PQS$, we have

$$PQ + QS > PS \quad \dots(1)$$

[\therefore Sum of the lengths of any two sides of a triangle must be greater than the third side]

Now, in $\triangle PSR$, we have

$$RS + RP > PS \quad \dots(2) \quad \text{[\therefore Sum of the lengths of any two sides of a triangle must be greater than the third side]}$$

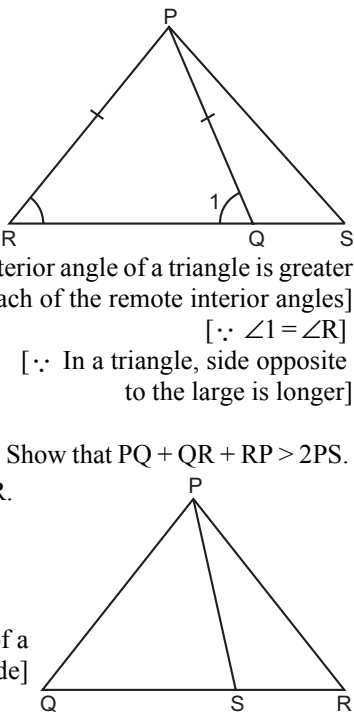

Adding (1) and (2), we get

$$PQ + QS + RS + RP > 2PS$$

$$\Rightarrow PQ + QR + RP > 2PS$$

Hence, proved

7. D is any point on side AC of a $\triangle ABC$ with $AB = AC$. Show that $CD < BD$.

Sol. In $\triangle ABC$, we have

$$AB = AC \quad [\text{Given}]$$

$$\therefore \angle ABC = \angle ACB$$

[\because Angles opp. to equal sides of a triangle are equal]

$$\text{Now, } \angle DBC < \angle ABC$$

$$\therefore \angle DBC < \angle ACB \text{ or } \angle DBC < \angle DCB$$

Hence, $CD < BD$. [\because Side opposite to greater angle is longer]

8. In the given figure, $l \parallel m$ and M is the mid-point of the line segment AB. Prove that M is also the mid-point of any line segment CD having its end-points on l and m respectively.

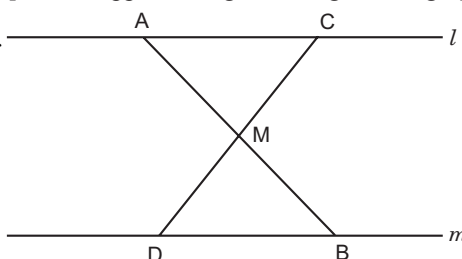

Sol. In $\triangle AMC$ and $\triangle BMD$, we have

$$\angle 1 = \angle 3$$

[Alt. \angle s because $l \parallel m$]

$$\angle 2 = \angle 4$$

[Vert. opp. \angle s]

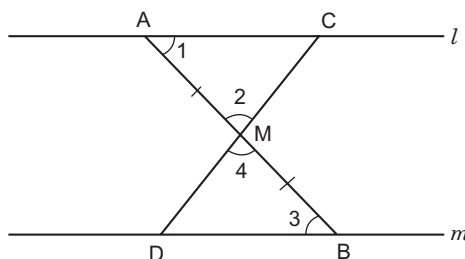

$$AM = BM \quad [\text{Given}]$$

$$\therefore \triangle AMC \cong \triangle BMD \quad [\text{By AAS congruence rule}]$$

$$\therefore CM = DM \quad [\text{CPCT}]$$

Hence, M is also the mid-point of CD

9. Bisectors of the angles B and C of an isosceles triangle with $AB = AC$ intersect each other at O. BO is produced to a point M. Prove that $\angle MOC = \angle ABC$.

Sol. Bisectors of the angles B and C of an isosceles triangle ABC with $AB = AC$ intersect each other at O. BO is produced to a point M.

In $\triangle ABC$, we have

$$AB = AC$$

$$\therefore \angle ABC = \angle ACB$$

[\because Angles opposite to equal sides of a triangle are equal]

$$\Rightarrow \frac{1}{2} \angle ABC = \frac{1}{2} \angle ACB,$$

i.e., $\angle 1 = \angle 2$ [\because BO and CO are bisectors of $\angle B$ and $\angle C$]

In $\triangle OBC$, Ext. $\angle MOC = \angle 1 + \angle 2$

[\because Exterior angle of a triangle is equal to the sum of interior opposite angles]

$$\Rightarrow \text{Ext. } \angle MOC = 2\angle 1 \quad [\because \angle 1 = \angle 2]$$

Hence, $\angle MOC = \angle ABC$.

- 10.** Bisectors of the angles B and C of an isosceles triangle ABC with $AB = AC$ intersect each other at O. Show that external angle adjacent to $\angle ABC$ is equal to $\angle BOC$.

Sol. In $\triangle ABC$, we have

$$AB = AC$$

$$\therefore \angle B = \angle C$$

[\because Angles opposite to equal sides of a triangle are equal]

$$\therefore \frac{1}{2} \angle B = \frac{1}{2} \angle C \quad \dots(1)$$

In $\triangle OBC$, we have

$$\angle 1 = \frac{1}{2} \angle B$$

and $\angle 2 = \frac{1}{2} \angle C$

$$\therefore \angle 1 = \angle 2$$

$$\angle DBC + \angle 1 + \angle OBA = 180^\circ$$

$$\Rightarrow \angle DBC + 2\angle 1 = 180^\circ$$

In $\triangle OBC$,

$$\angle 1 + \angle 2 + \angle BOC = 180^\circ$$

$$\Rightarrow 2\angle 1 + \angle BOC = 180^\circ$$

[$\because \angle 1 = \angle 2$]... (2)

From (1) and (2), we get

$$\angle DBC + 2\angle 1 = 2\angle 1 + \angle BOC$$

$$\Rightarrow \angle DBC = \angle BOC$$

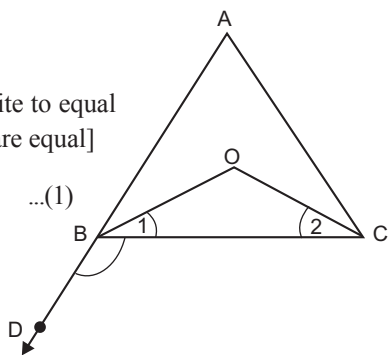
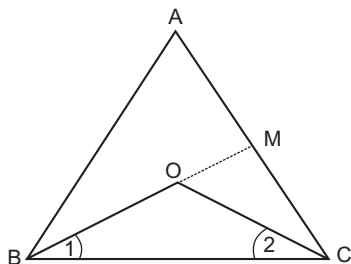

11. In the given figure, AD is the bisector of $\angle BAC$. Prove that $AB > BD$.

Sol. Since exterior angle of a triangle is greater than either of the interior opposite angles, therefore, in $\triangle ACD$,
Ext. $\angle 3 > \angle 2 \Rightarrow \angle 3 > \angle 1$

[\because AD is the bisector of $\angle BAC$,
so $\angle 1 = \angle 2$]

Now, in $\triangle ABD$, we have

$$\angle 3 > \angle 1$$

Hence, $AB > BD$. [\because In a triangle, side opposite to greater angle is longer]

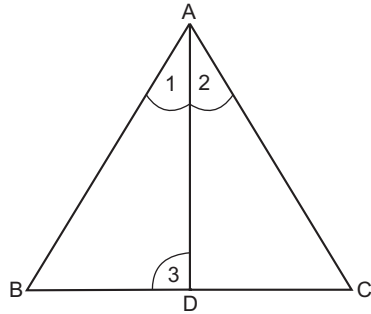

EXERCISE 7.4

1. Find all the angles of an equilateral triangle.

Sol. In $\triangle ABC$, we have

$$AB = AC$$

$$\Rightarrow \angle C = \angle B \quad \dots(1)$$

[\because Angles opposite to equal sides of a triangle are equal]

$$BC = AC$$

$$\Rightarrow \angle A = \angle B \quad \dots(2)$$

[\because Angles opposite to equal sides of a triangle are equal]

$$\text{Now, } \angle A + \angle B + \angle C = 180^\circ \quad [\because \text{Angle sum property of a triangle}]$$

$$\Rightarrow \angle A + \angle A + \angle A = 180^\circ \quad [\text{From (1) and (2)}]$$

$$\Rightarrow 3\angle A = 180^\circ$$

$$\Rightarrow \angle A = \frac{180^\circ}{3} = 60^\circ$$

$$\therefore \angle A = \angle B = \angle C = 60^\circ$$

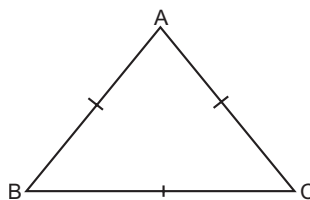

2. The image of an object placed at a point A before a plane mirror LM is seen at the point B by an observer at D as shown in the given figure. Prove that the image is as far behind the mirror as the object is in front of the mirror.

[**Hint:** CN is normal to the mirror.

Also, angle of incidence = angle of reflection].

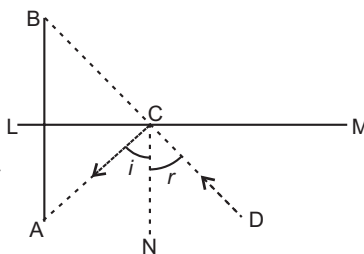

Sol. Let AB intersect LM at O. We have to prove that $AO = BO$.

$$\text{Now, } \angle i = \angle r \quad \dots(1)$$

[\because Angle of incidence = Angle of reflection]

and $\angle B = \angle i$ [Corres. \angle s]...(2)
 $\angle A = \angle r$ [Alternate int. \angle s]...(3)
 From (1), (2) and (3), we get
 $\angle B = \angle A$
 $\Rightarrow \angle BCO = \angle ACO$

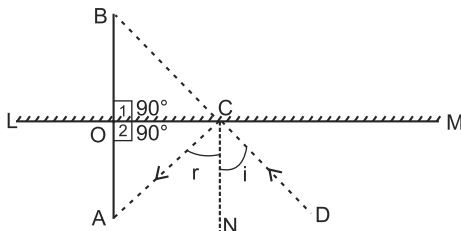

In $\triangle BOC$ and $\triangle AOC$, we have
 $\angle 1 = \angle 2$ [Each = 90°]
 $OC = OC$ [Common side]
 and $\angle BCO = \angle ACO$ [Proved above]
 $\therefore \triangle BOC \cong \triangle AOC$ [ASA congruence rule]
 Hence, $AO = BO$ [CPCT]

3. ABC is an isosceles triangle with $AB = AC$ and D is a point on BC such that $AD \perp BC$ (See fig.). To prove that $\angle BAD = \angle CAD$, a student proceeded as follows:

In $\triangle ABD$ and $\triangle ACD$,
 $AB = AC$ (Given)
 $\angle B = \angle C$ (because $AB = AC$)
 and $\angle ADB = \angle ADC$

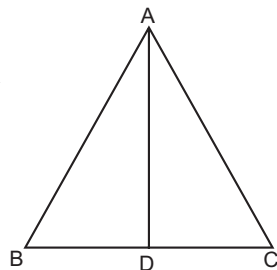

Therefore,
 $\triangle ABD = \triangle ACD$ (AAS)
 So, $\angle BAD = \angle CAD$ (CPCT)

What is the defect in the above arguments?
[Hint: Recall how $\angle B = \angle C$ is proved when $AB = AC$]

Sol. In $\triangle ADB$ and $\triangle ADC$, we have

$\angle ADB = \angle ADC$
 [\therefore Each equal to 90°]

$AB = AC$ [Given]

$AD = AD$ [Common side]

So, by RHS criterion of congruence, we have

$\triangle ADB \cong \triangle ADC$

$\therefore \angle BAD = \angle CAD$ [CPCT]

Hence, proved.

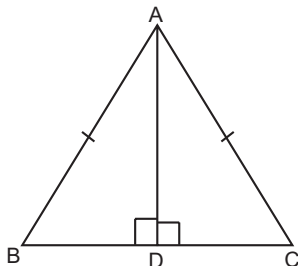

4. P is a point on the bisector of $\angle ABC$. If the line through P, parallel to BA meet BC at Q, prove that BPQ is an isosceles triangle.

Sol. We have to prove that BPQ is an isosceles triangle.

$$\angle 1 = \angle 2 \quad \dots(1)$$

[\because BP is the bisector of $\angle ABC$]

Now, PQ is parallel to BA and BP cuts them

$$\therefore \angle 1 = \angle 3$$

[Alt. \angle s] ... (2)

From (1) and (2), we get

$$\angle 2 = \angle 3$$

In $\triangle BPQ$, we have

$$\angle 2 = \angle 3 \quad \text{[Proved above]}$$

$$\therefore PQ = BQ \quad \text{[\because Sides opp. to equal angles are equal]}$$

Hence, BPQ is an isosceles triangle.

5. ABCD is a quadrilateral in which $AB = BC$ and $AD = CD$. Show that BD bisects both the angles ABC and ADC.

Sol. In $\triangle ABD$ and $\triangle CBD$, we have

$$AB = BC \quad \text{[Given]}$$

$$AD = CD \quad \text{[Given]}$$

$$BD = BD \quad \text{[Common side]}$$

$$\therefore \triangle ABD \cong \triangle CBD \quad \text{[By SSS congruence rule]}$$

$$\Rightarrow \angle 1 = \angle 2 \quad \text{[CPCT]}$$

$$\text{and } \angle 3 = \angle 4$$

Hence, BD bisects both the angles ABC and ADC.

6. ABC is a right triangle with $AB = AC$. Bisector of $\angle A$ meets BC at D. Prove that $BC = 2AD$.

Sol. Given : A right angled triangle with $AB = AC$ and bisector of $\angle A$ meets BC at D.

To prove: $BC = 2AD$

Proof : In right $\triangle ABC$,

$$AB = AC \quad \text{[Given]}$$

\Rightarrow BC is hypotenuse

[\because Hypotenuse is the longest side.]

$$\therefore \angle BAC = 90^\circ$$

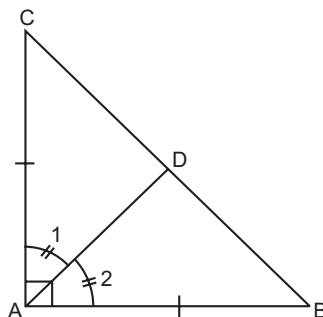
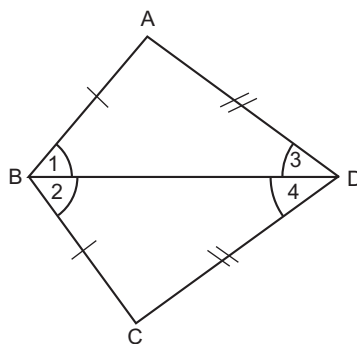
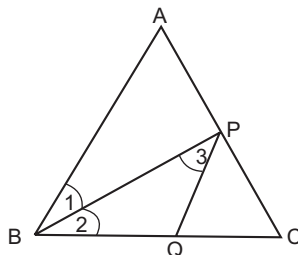

Now, in $\triangle CAD$ and $\triangle BAD$, we have

$$\begin{aligned} AC &= AB && \text{[Given]} \\ \angle 1 &= \angle 2 && [\because AD \text{ is the bisector of } \angle A] \\ AD &= AD && \text{[Common side]} \end{aligned}$$

So, by SAS criterion of congruence, we have

$$\triangle CAD \cong \triangle BAD$$

$$\begin{aligned} \therefore CD &= BD && \text{[CPCT]} \\ \Rightarrow AD &= BD = CD && \dots(1) \end{aligned}$$

$[\because \text{Mid-point of hypotenuse of a rt. } \Delta \text{ is equidistant from the three vertices of a } \Delta]$

$$\begin{aligned} \text{Now, } BC &= BD + CD \\ \Rightarrow BC &= AD + AD && \text{[Using (1)]} \\ \Rightarrow BC &= 2AD \end{aligned}$$

Hence, proved.

7. O is a point in the interior of a square ABCD such that OAB is an equilateral triangle. Show that $\triangle OCD$ is an isosceles triangle.

Sol. Given: A square ABCD and $OA = OB = AB$.

To prove: $\triangle OCD$ is an isosceles triangle.

Proof: In square ABCD,

$$\begin{aligned} \angle 1 &= \angle 2 && \dots(1) \\ &&& [\because \text{Each equal to } 90^\circ] \end{aligned}$$

Now, in $\triangle OAB$, we have

$$\angle 3 = \angle 4 && \dots(2)$$

Subtracting (2) from (1), we get

$$\angle 1 - \angle 3 = \angle 2 - \angle 4$$

$$\Rightarrow \angle 5 = \angle 6$$

Now, in $\triangle DAO$ and $\triangle CBO$,

$$\begin{aligned} AD &= BC && \text{[Given]} \\ \angle 5 &= \angle 6 && \text{[Proved above]} \\ OA &= OB && \text{[Given]} \end{aligned}$$

So, by SAS criterion of congruence, we have

$$\triangle DAO \cong \triangle CBO$$

$$\begin{aligned} \therefore OD &= OC \\ \Rightarrow \triangle OCD &\text{ is an isosceles triangle.} \end{aligned}$$

Hence, proved.

8. ABC and DCB are two triangles on the same base BC such that A and D lie on the opposite sides of BC, $AB = AC$ and $DB = DC$. Show that AD is the perpendicular bisector of BC.

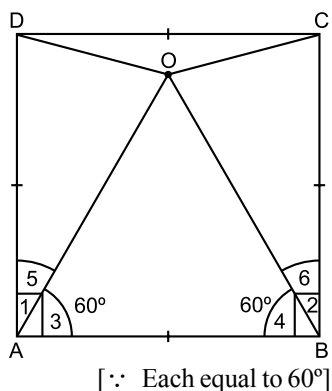

Sol. Given : $\triangle ABC$ and $\triangle DBC$ on the same base BC . Also, $AB = AC$ and $DB = DC$.

To prove : AD is the perpendicular bisector of BC i.e., $OB = OC$

Proof : In $\triangle BAD$ and $\triangle CAD$, we have

$$AB = AC \quad [\text{Given}]$$

$$BD = CD \quad [\text{Given}]$$

$$AD = AD$$

[Common side]

So, by SSS criterion of congruence, we have

$$\triangle BAD \cong \triangle CAD$$

$$\therefore \angle 1 = \angle 2 \quad [\text{CPCT}]$$

Now, in $\triangle BAO$ and $\triangle CAO$, we have

$$AB = AC \quad [\text{Given}]$$

$$\angle 1 = \angle 2 \quad [\text{Proved above}]$$

$$AO = AO \quad [\text{Common side}]$$

So, by SAS criterion of congruence, we have

$$\triangle BAO \cong \triangle CAO$$

$$\therefore BO = CO \quad [\text{CPCT}]$$

$$\text{and } \angle 3 = \angle 4 \quad [\text{CPCT}]$$

$$\text{But, } \angle 3 + \angle 4 = 180^\circ \quad [\text{Linear pair axiom}]$$

$$\Rightarrow \angle 3 + \angle 3 = 180^\circ$$

$$\Rightarrow 2\angle 3 = 180^\circ$$

$$\Rightarrow \angle 3 = \frac{180^\circ}{2} = 90^\circ$$

$\therefore AD$ is perpendicular bisector of BC [$\because BO = CO$ and $\angle 3 = 90^\circ$]

Hence, proved.

9. ABC is an isosceles triangle in which $AC = BC$. AD and BE are respectively two altitudes to the sides BC and AC . Prove that $AE = BD$.

Sol. In $\triangle ADC$ and $\triangle BEC$, we have

$$AC = BC$$

$$\angle ADC = \angle BEC$$

$$\angle ACD = \angle BCE$$

$$\therefore \triangle ADC \cong \triangle BEC$$

[By AAS congruence rule]

$$\therefore CE = CD \quad \dots(2) [\text{CPCT}]$$

Subtracting (2) from (1), we get

$$AC - CE = BC - CD$$

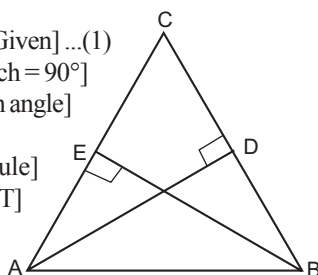
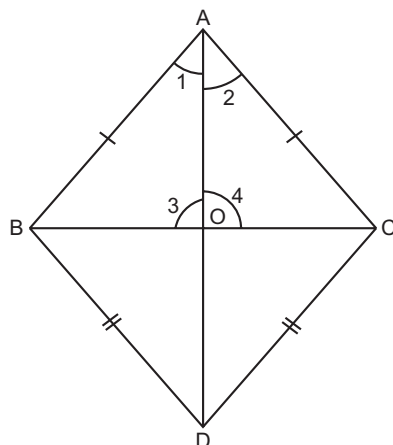

$$\Rightarrow AE = BD$$

Hence, proved.

- 10.** Prove that sum of any two sides of a triangle is greater than twice the median with respect to the third side.

Sol. Given : $\triangle ABC$ with median AD .

To prove :

$$AB + AC > 2AD$$

$$AB + BC > 2AD$$

$$BC + AC > 2AD$$

Construction: Produce AD to E such that $DE = AD$ and join EC .

Proof : In $\triangle ADB$ and $\triangle EDC$,

$$AD = ED$$

$$\angle 1 = \angle 2$$

$$DB = DC \quad [\text{Given}]$$

So, by SAS criterion of congruence, we have

$$\triangle ADB \cong \triangle EDC$$

$$\therefore AB = EC \quad [\text{CPCT}]$$

$$\text{and, } \angle 3 = \angle 4 \quad [\text{CPCT}]$$

Now, in $\triangle AEC$, we have

$$AC + CE > AE$$

[\because Sum of the lengths of any two sides of a triangle must be greater than the third side]

$$\Rightarrow AC + CE > AD + DE$$

$$\Rightarrow AC + CE > AD + AD \quad [\because AD = DE]$$

$$\Rightarrow AC + CE > 2AD$$

$$\Rightarrow AC + AB > 2AD \quad [\because AB = EC]$$

Hence, proved.

Similarly, $AB + BC > 2AD$ and $BC + AC > 2AD$.

- 11.** Show that in a quadrilateral $ABCD$, $AB + BC + CD + DA < 2(BD + AC)$.

Sol. Given : A quadrilateral $ABCD$.

To prove :

$$AB + BC + CD + DA < 2(BD + AC)$$

Proof : In $\triangle AOB$, we have

$$\Rightarrow OA + OB > AB \quad \dots(1)$$

[\because Sum of the lengths of any two sides of a triangle must be greater than the third side]

In $\triangle BOC$, we have

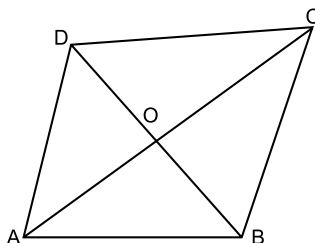
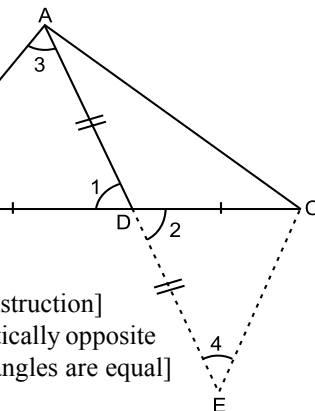

$$OB + OC > BC \quad \dots(2) \text{ [Same reason]}$$

In $\triangle COD$, we have

$$OC + OD > CD \quad \dots(3) \text{ [Same reason]}$$

In $\triangle DOA$, we have

$$OD + OA > DA \quad \dots(4) \text{ [Same reason]}$$

Adding (1), (2), (3) and (4), we get

$$OA + OB + OB + OC + OC + OD + OD + OA > AB + BC + CD + DA$$

$$\Rightarrow 2(OA + OB + OC + OD) > AB + BC + CD + DA$$

$$\Rightarrow 2\{(OA + OC) + (OC + OD)\} > AB + BC + CD + DA$$

$$\Rightarrow 2(AC + BD) > AB + BC + CD + DA$$

$$\Rightarrow AB + BC + CD + DA < 2(BD + AC)$$

Hence, proved.

12. Show that in a quadrilateral ABCD.

$$AB + BC + CD + DA > AC + BD$$

Sol. Given : A quadrilateral ABCD.

To prove : $AB + BC + CD + DA > AC + BD$

Proof : In $\triangle ABC$, we have

$$AB + BC > AC \quad \dots(1)$$

[\because Sum of the lengths of any two sides of a triangle must be greater than the third side]

In $\triangle BCD$, we have

$$BC + CD > BD \quad \dots(2) \text{ [Same reason]}$$

In $\triangle CDA$, we have

$$CD + DA > AC \quad \dots(3) \text{ [Same reason]}$$

In $\triangle DAB$, we have

$$AD + AB > BD \quad \dots(4) \text{ [Same reason]}$$

Adding (1), (2), (3) and (4), we get

$$AB + BC + BC + CD + CD + DA + AD + AB > AC + BD + AC + BD$$

$$\Rightarrow 2AB + 2BC + 2CD + 2DA > 2AC + 2BD$$

$$\Rightarrow 2(AB + BC + CD + DA) > 2(AC + BD)$$

$$\Rightarrow AB + BC + CD + DA > AC + BD$$

Hence, proved.

13. In a triangle ABC, D is the mid-point of side AC such that $BD = \frac{1}{2} AC$.

Show that $\angle ABC$ is a right angle.

Sol. We have to prove that $\angle ABC = 90^\circ$.

As D is the mid-point of AC,

$$\text{so, } AD = DC$$

$$\text{Also, } BD = \frac{1}{2} AC = AD \quad [\because D \text{ is the mid-point of AC}]$$

$$\therefore BD = AD = DC$$

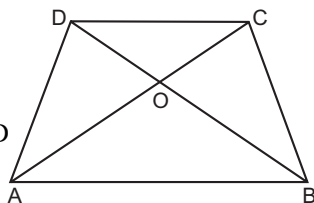

In $\triangle ABD$, we have

$$BD = AD$$

$$\therefore \angle 1 = \angle 2 \quad \dots(1)$$

[\because Angles opposite to equal sides are equal]

In $\triangle BDC$, we have

$$BD = DC,$$

$$\therefore \angle 3 = \angle 4$$

$$\dots(2)$$

[\because Angles opposite to equal sides are equal]

In $\triangle ABC$, we have

$$\angle 1 + \angle ABC + \angle 4 = 180^\circ$$

$$\Rightarrow \angle 1 + \angle 2 + \angle 3 + \angle 4 = 180^\circ \quad [\because \angle ABC = \angle 3 + \angle 2]$$

$$\Rightarrow 2(\angle 2 + \angle 3) = 180^\circ$$

$$\Rightarrow \angle 2 + \angle 3 = 90^\circ \quad [\text{By (1) and (2)}]$$

$$\Rightarrow \angle ABC = 90^\circ$$

Hence, proved.

- 14.** In a right triangle, prove that the line segment joining the mid-point of the hypotenuse to the opposite vertex is half the hypotenuse.

Sol. ABC is a right triangle, right angled at B and D is the mid-point of AC. We have to prove that

$$BD = \frac{1}{2} AC.$$

Now, produce BD to E such that $BD = DE$. Join EC.

In $\triangle ADB$ and $\triangle CDE$, we have

$$AD = CD$$

[\because D is the mid-point of AC]

$$\angle ADB = \angle CDE$$

[Vertically opposite \angle s]

$$BD = DE$$

[By construction]

$$\therefore \triangle ADB \cong \triangle CDE \quad [\text{By SAS criterion of congruence}]$$

$$\therefore AB = EC \quad [\text{CPCT}]$$

$$\text{and } \angle 1 = \angle 2 \quad [\text{CPCT}]$$

But, $\angle 1$ and $\angle 2$ are alternate angles.

$$\therefore EC \parallel BA$$

Now, EC is parallel to BA and BC is the transversal

$$\therefore \angle ABC + \angle BCE = 180^\circ$$

$$\Rightarrow 90^\circ + \angle BCE = 180^\circ$$

$$\Rightarrow \angle BCE = 180^\circ - 90^\circ = 90^\circ$$

In $\triangle ABC$ and $\triangle ECB$, we have

$$BC = BC$$

[Common side]

$$AB = EC$$

[Proved above]

$$\angle CBA = \angle BCE$$

[\because Each $= 90^\circ$]

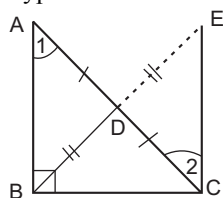
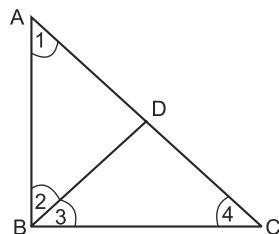

$$\begin{aligned} \therefore \quad \triangle ABC &\cong \triangle EBC && \text{[By SAS criterion of congruence]} \\ \therefore \quad AC &= EB && \text{[CPCT]} \\ \Rightarrow \quad \frac{1}{2} AC &= \frac{1}{2} EB \Rightarrow \frac{1}{2} AC = BD \end{aligned}$$

Hence, $BD = \frac{1}{2} AC$.

15. Two lines l and m intersect at the point O and P is a point on a line n passing through the point O such that P is equidistant from l and m . Prove that n is the bisector of the angle formed by l and m .

Sol. Given : Lines l, m and n intersect at point O . P is a point on line n such that P is equidistant from l and n .

To prove : n is the bisector of $\angle QOR$.

Proof : In $\triangle OQP$ and $\triangle ORP$, we have

$$\angle 1 = \angle 2$$

[\because Each equal to 90°]

$$OP = OP \quad \text{[Common side]}$$

$$PQ = PR \quad \text{[Given]}$$

So, by RHS criterion of congruence, we have

$$\triangle OQP \cong \triangle ORP$$

$$\therefore \quad \angle 3 = \angle 4 \quad \text{[CPCT]}$$

So, n is bisector of $\angle QOR$.

Hence, proved.

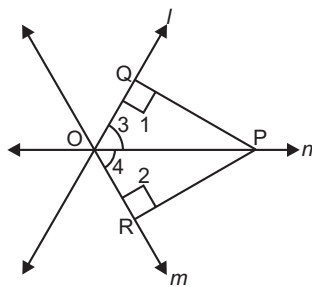

16. Line-segment joining the mid-points M and N of parallel sides AB and DC respectively of trapezium $ABCD$ is perpendicular to both the sides AB and DC . Prove that $AD = BC$.

Sol. Join MD and CM .

We have, $\angle DNM = \angle NMB$ [Alt. \angle s]
 $\because AB \parallel CD$

Now, in $\triangle DMN$ and $\triangle CNM$,

$$CN = DN$$

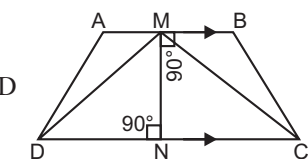

[\because N is the mid-point of DC]

$$\angle DNM = \angle CNM \quad \text{[Each } = 90^\circ\text{]}$$

$$NM = NM \quad \text{[Common side]}$$

$$\therefore \quad \triangle DMN \cong \triangle CNM \quad \text{[By SAS congruence rule]}$$

$$\therefore \quad DM = CM \text{ and } \angle NMC = \angle NMD \dots (1) \text{ [CPCT]}$$

$$\text{Now,} \quad \angle AMN = \angle BMN \quad \text{[Each } = 90^\circ\text{]}$$

$$\text{and} \quad \angle NMD = \angle NMC \quad \text{[Proved above]}$$

$$\therefore \quad \angle AMN - \angle NMD = \angle BMN - \angle NMC \quad \text{[on subtraction]}$$

\Rightarrow $\angle AMD = \angle BMC$... (2)
 $AM = BM$ [Given]
 $DM = CM$ [From (1)]
 $\angle AMD = \angle BMC$ [From (2)]
 $\triangle AMD \cong \triangle BMC$ [By SAS congruence rule]
 $\therefore AD = BC$ [CPCT]

17. ABCD is a quadrilateral such that diagonal AC bisects the angles A and C. Prove that AB = AD and CB = CD.

Ans. Given : A quadrilateral ABCD such that $\angle 1 = \angle 2$ and $\angle 3 = \angle 4$.

To prove : AB = AD and CB = CD

Proof : In $\triangle ABC$ and $\triangle ADC$, we have

$\angle 1 = \angle 2$ [Given]
 $AC = AC$ [Common side]
 $\angle 3 = \angle 4$ [Given]

So, by ASA criterion of congruence, we have

$\triangle ABC \cong \triangle ADC$

$\therefore AB = AD$ [CPCT]

and $CB = CD$ [CPCT]

Hence, proved.

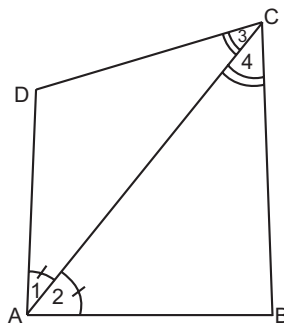

18. ABC is a right triangle such that AB = AC and bisector of angle C intersects the side AB at D. Prove that AC + AD = BC.

Sol. Given : A right triangle ABC, AB = AC and CD is the bisector of $\angle C$.

To prove : AC + AD = BC

Construction: Draw $DE \perp BC$.

Proof : In right triangle ABC, we have

$AB = AC$ [Given]

$\therefore BC$ is hypotenuse

$\Rightarrow \angle A = 90^\circ$

In $\triangle DAC$ and $\triangle DEC$, we have

$\angle A = \angle 3$ [\because Each equal to 90°]

$\angle 1 = \angle 2$ [Given]

$DC = DC$ [Common side]

So, by AAS criterion of congruence, we have

$\triangle DAC \cong \triangle DEC$

$\therefore DA = DE$... (1) [CPCT]

and $CA = CE$... (2) [CPCT]

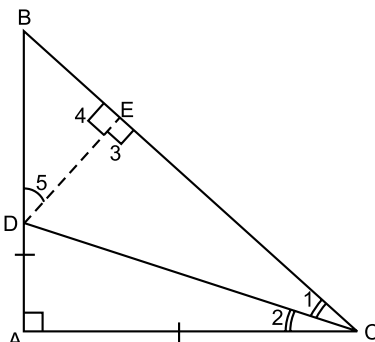

In $\triangle BAC$, we have

$$\begin{aligned} & AB = AC && \text{[Given]} \\ \Rightarrow & \angle C = \angle B && [\because \text{Angles opposite to equal sides of} \\ & && \text{a triangle are equal}] \end{aligned}$$

Now, $\angle A + \angle B + \angle C = 180^\circ$ [Angle sum property of a triangle]

$$\Rightarrow 90^\circ + \angle B + \angle B = 180^\circ \quad [\because \angle B = \angle C]$$

$$\Rightarrow 2\angle B = 90^\circ$$

$$\Rightarrow \angle B = \frac{90^\circ}{2} = 45^\circ$$

Now, in $\triangle BED$, we have

$$\Rightarrow \angle 4 + \angle 5 + \angle B = 180^\circ \quad \text{[Angle sum property of a triangle]}$$

$$\Rightarrow 90^\circ + \angle 5 + 45^\circ = 180^\circ$$

$$\Rightarrow \angle 5 = 180^\circ - 135^\circ$$

$$\Rightarrow \angle 5 = 45^\circ$$

$$\therefore \angle B = \angle 5$$

$$\Rightarrow DE = BE \quad \dots(3) \quad [\because \text{Sides opposite to equal angles} \\ \text{of a triangle are equal}]$$

From (1) and (3), we get

$$DA = DE = BE \quad \dots(4)$$

Now,

$$BC = CE + BE$$

$$\Rightarrow BC = CA + DA \quad \text{[Using (2), (3) and (4)]}$$

$$\Rightarrow BC = AC + AD$$

$$\Rightarrow AC + AD = BC$$

Hence, proved.

19. AB and CD are the smallest and largest sides of a quadrilateral ABCD. Out of $\angle B$ and $\angle D$ decide which is greater.

Sol. Given: A quadrilateral ABCD in which AB and CD are the smallest and largest sides of quadrilateral ABCD.

To prove: $\angle B > \angle D$

Construction: Join BD.

Proof: In $\triangle ABD$, we have

$$\Rightarrow AB < AD$$

[\because AB is the smallest side of quadrilateral ABCD]

$$\Rightarrow AD > AB$$

$$\Rightarrow \angle ABD > \angle ADB \quad \dots(1) \quad [\because \text{Angle opposite to longest side is greater}]$$

Again, in $\triangle CBD$, we have

$$CD > BC \quad [\because \text{CD is the longest side of quadrilateral ABCD}]$$

$$\Rightarrow \angle CBD > \angle BDC \quad \dots(2) \quad [\because \text{Angle opposite to longest side is greater}]$$

Adding (1) and (2), we get

$$\angle ABD + \angle CBD > \angle ADB + \angle BDC$$

$$\Rightarrow \angle ABC > \angle ADC$$

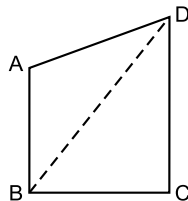

$$\Rightarrow \angle B > \angle D$$

Hence, proved.

- 20.** Prove that in a triangle, other than an equilateral triangle, angle opposite the longest side is greater than $\frac{2}{3}$ of a right angle.

Sol. Given : A triangle ABC, other than an equilateral triangle.

$$\text{To prove : } \angle A > \frac{2}{3} \text{rt. } \angle$$

Proof : In $\triangle ABC$, we have

$$BC > AB$$

$$\Rightarrow \angle A > \angle C$$

...(1) [\because In a triangle, angle opposite to the longer side is larger]

$$BC > AC$$

$$\Rightarrow \angle A > \angle B$$

...(2) [\because In a triangle, angle opposite to the longer side is larger]

Adding (1) and (2), we get

$$\angle A + \angle A > \angle B + \angle C$$

$$\Rightarrow 2\angle A > \angle B + \angle C$$

Now, adding $\angle A$ on both sides, we get

$$2\angle A + \angle A > \angle A + \angle B + \angle C$$

$$\Rightarrow 3\angle A > \angle A + \angle B + \angle C$$

$$\Rightarrow 3\angle A > 180^\circ \quad [\text{Angle sum property of a triangle}]$$

$$\Rightarrow \angle A > \frac{180^\circ}{3}$$

$$\Rightarrow \angle A > \frac{2}{3} \times 90^\circ$$

$$\Rightarrow \angle A > \frac{2}{3} \text{rt. } \angle$$

Hence, proved.

- 21.** ABCD is quadrilateral such that $AB = AD$ and $CB = CD$. Prove that AC is the perpendicular bisector of BD.

Sol. Given : A quadrilateral ABCD in which $AB = AD$ and $CB = CD$.

To prove : AC is the perpendicular bisector of BD.

Proof : In $\triangle ABC$ and $\triangle ADC$, we have

$$AB = AD \quad [\text{Given}]$$

$$BC = CD \quad [\text{Given}]$$

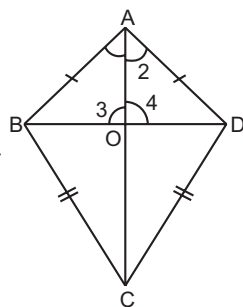
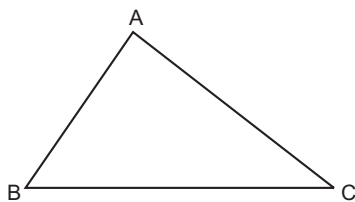

$$AC = AC \quad [\text{Common side}]$$

So, by SSS criterion of congruence, we have

$$\triangle ABC \cong \triangle ADC$$

$$\therefore \angle 1 = \angle 2 \quad [\text{CPCT}]$$

Now, in $\triangle AOB$ and $\triangle AOD$, we have

$$AB = AD \quad [\text{Given}]$$

$$\angle 1 = \angle 2 \quad [\text{Proved above}]$$

$$AO = AO \quad [\text{Common side}]$$

So, by SAS criterion of congruence, we have

$$\triangle AOB \cong \triangle AOD$$

$$\therefore BO = DO \quad [\text{CPCT}]$$

$$\text{and } \angle 3 = \angle 4 \quad [\text{CPCT}]$$

$$\text{But, } \angle 3 + \angle 4 = 180^\circ \quad [\text{Linear pair axiom}]$$

$$\Rightarrow \angle 3 + \angle 3 = 180^\circ \quad [\because \angle 3 = \angle 4]$$

$$\Rightarrow 2\angle 3 = 180^\circ$$

$$\Rightarrow \angle 3 = \frac{180^\circ}{2} = 90^\circ$$

\therefore AC is perpendicular bisector of BC [$\because \angle 3 = 90^\circ$ and $BO = DO$]

Hence, proved.